

Trackit Optical Tracking 3D Scanner

Quick Start Guide

V3.0

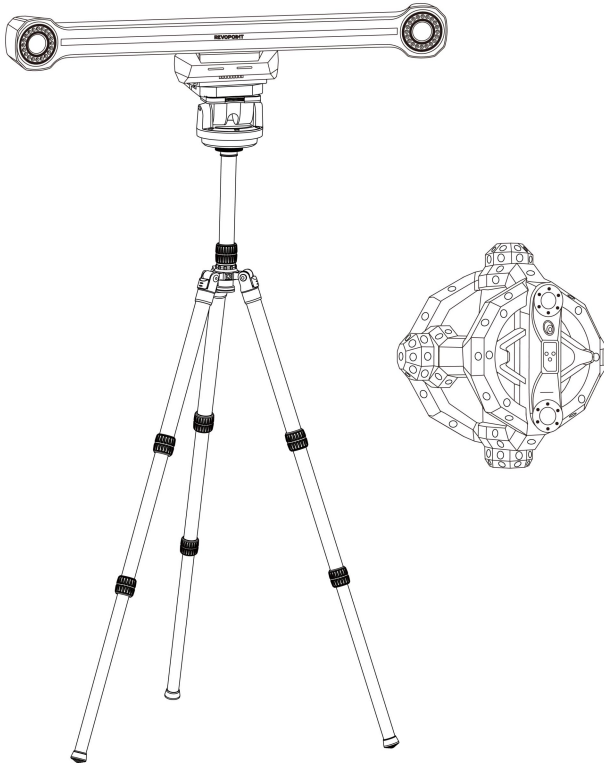

Thank you for choosing a Revopoint 3D scanner! Please carefully read this Quick Start Guide before your first scan.

Begin by downloading the **Revo Track** software for your PC from the Support - Download section on Revopoint's website at global.revopoint3d.com for your Trackit 3D scanner.

Go to the bottom of the Download page to get the latest Quick Start Guide.

Visit Revopedia for the Trackit User Manual.

Follow our YouTube account, Revopoint 3D, for tutorial videos.

This content is subject to change. Please refer to the latest version

This product complies with IEC 60825-1:2014.

It is classified as a CLASS 1 LASER PRODUCT (450 nm, maximum output power < 0.39 mW)

Contents

 What's in the Box	1
 Product Profile	2
 System Requirements	3
 Warnings	3
 Installation and Connection	4
Set Up Tracker's Tripod	4
Install Tracker	5
Connect Tracker	6
Connect Scanner	6
Power Trackit	7
Secure the Cables	7
 Calibration	8
Scanner Calibration	8
Tracker Calibration	9
Hand-Eye Calibration	9
 Your First Scan	11
Track Scan	11
Multi-position Scan	12
Marker Scan	13
Appendix 1: Specifications	14
Appendix 2: Mounting Hole Diagram	15
IC Warning	16
FCC Warning	16

What's in the Box

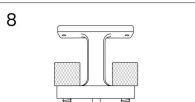
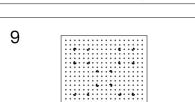
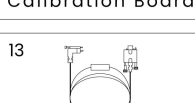
 <p>Tracker</p>	 <p>Scanner</p>	 <p>Tracker Auto Calibration Dual-axis Gimbal</p>	 <p>Scanner Auto Calibration Dual-axis Gimbal</p>
 <p>Tracker Tripod</p>	 <p>Scanner Tripod</p>	 <p>Calibration Board Tripod</p>	 <p>Scanner Adapter</p>
 <p>Calibration Board</p>	 <p>Calibration Pole</p>	 <p>Power Adapter</p>	 <p>PC Cable</p>
 <p>Scanner Cable</p>	 <p>Scanner Gimbal Cable</p>	 <p>Tracker Gimbal Cable</p>	 <p>Cable Ties</p>
 <p>Markers (Magnetic)</p>	 <p>Anchor Block</p>	 <p>Positioning Pad</p>	 <p>SN: CBxxxxxxx CPxxxxxxx</p> <p>USB Flash Drive</p>
 <p>Suction Cup Cable Holder</p>	 <p>Tracker Case with Wheels</p>	 <p>Scanner Case with Wheels</p>	 <p>Quick Start Guide Certificate & Warranty</p>

*For Reference Only.

Note: The Power Adapter may vary depending on the country or region.
Please store the product and all the accessories properly. Damaged components need to be sent back to Revopoint for repair.

Product Profile

Scanner

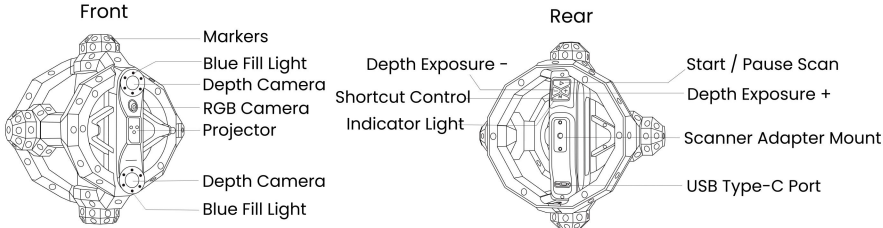

Tracker

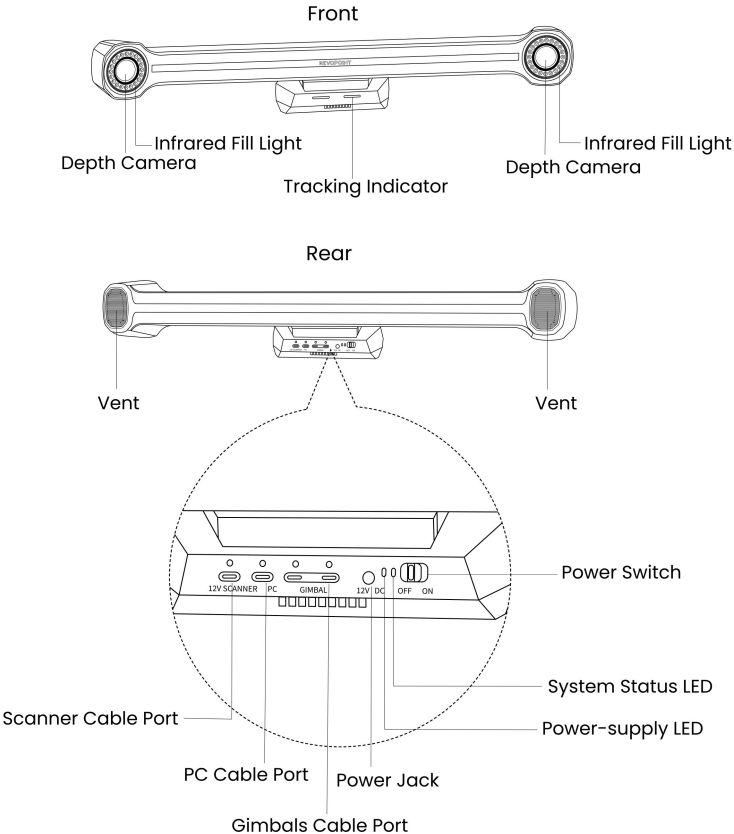

System Requirements

Minimum PC Requirements	Recommended PC Requirements
System Version: Windows 10/11 (64-bit) RAM: ≥ 32 GB CPU: Intel i7 13th Gen or better/AMD Ryzen 7 above the 7000 series GPU: NVIDIA GeForce RTX 3050 (8 GB)	System Version: Windows 10/11 (64-bit) RAM: ≥ 64 GB CPU: Intel i9 12th Gen or better GPU: NVIDIA RTX 4060 (8 GB) or better

Note: The software is only compatible with x86_64 architecture. If you're unsure about the CPU configuration, please ensure that the CPU has cores ≥ 8, threads ≥ 16, and a base frequency ≥ 2.4GHz. Please ensure the USB port on your PC is USB 3.0 or above.

Warnings

- This product uses a Class 1 laser projector. Avoid looking directly at it at close range! Please refer to the Class 1 laser standard document for details. To prevent laser reflection, avoid placing reflective surfaces like mirrors or glass in the path of the laser beam.
- Please keep the scanner away from water and other liquids. Use the product in a dry and dust-free environment.
- To ensure accuracy, follow the environmental requirements below when operating the product:
 - ① Temperature: 20-25°C
 - ② Humidity: 30-60%
 - ③ Airflow: Avoid air turbulence, such as from air conditioning vents, fans, or strong convective air currents.
 - ④ Vibration: Avoid vibrations from activities like jumping, walking frequently, or heavy objects falling.
- Don't disassemble the product or its components.
- Both the Scanner Tripod and the Calibration Board Tripod legs have a single standard angle. Ensure all legs are set to this angle during use.
- Avoid holding or rubbing the markers on the device and accessories when using the product.
- Ensure the computer is connected to a power supply when using the product.
- Be sure to place the product and accessories in the case when transporting them. It's recommended that all unused products and accessories be stored in their case.

Installation and Connection

Set Up Tracker's Tripod

Step 1: Pull the legs outwards to unfold the tripod.

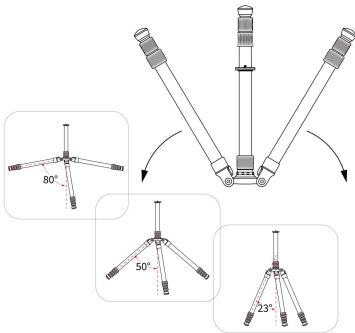
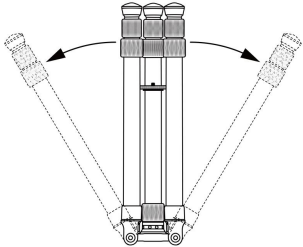

Step 2: Continue pulling the legs down until they lock into place. (A click sound indicates it has locked into one of the three preset positions shown in descending order.)

Step 3: Adjust the center column and the legs to your required height as shown in the diagram.

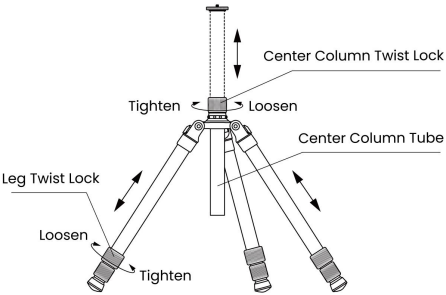

Note: If you need a wider leg spread, follow the steps in the diagram.

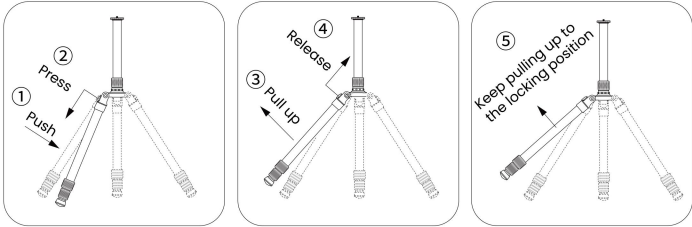

Install Tracker

> Calibration Scenario

Step 1: Align the Tracker Gimbal's screw hole with the tripod screw, then rotate the gimbal until securely attached to the tripod.

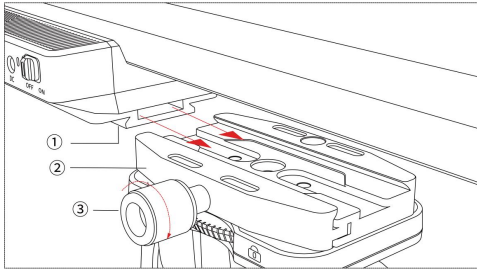
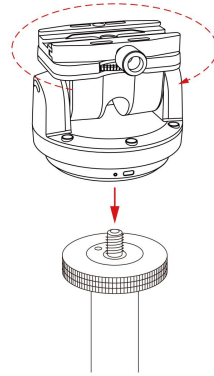

Step 2: Slide the Quick Release Plate¹ on the bottom of the Tracker into the groove of the Quick Release Clamp², and ensure the white lines on the front are aligned. Then, tighten the locking knob³ clockwise.

> Scanning Scenario

Step 1: The Tracker gimbal must be removed during scanning to avoid vibration. Please remove it from the Quick Release Clamp before scanning.

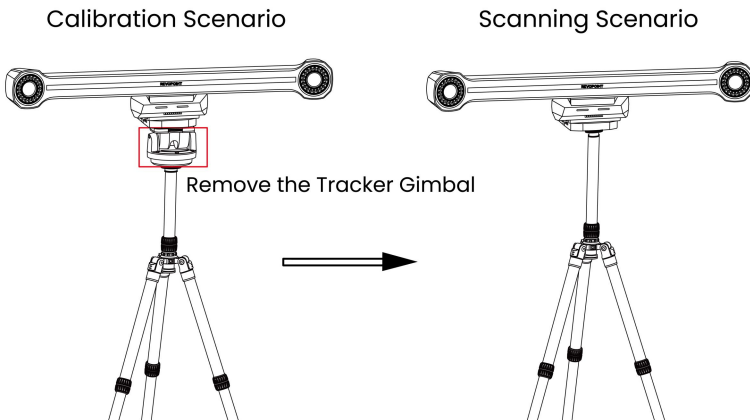

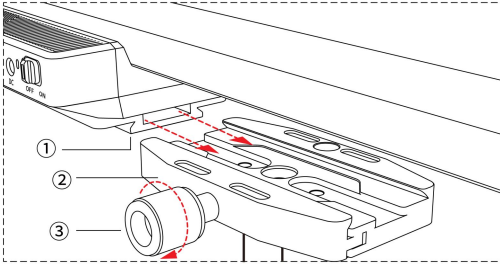

Step 2: Slide the Quick Release Plate¹ on the bottom of the Tracker into the groove of the Quick Release Clamp², and ensure the white lines on the front are aligned. Then, tighten the locking knob³ clockwise.

Connect Tracker

Step 1: Connect the Power Adapter's DC end to Tracker's "12V DC" port, and AC end to a power supply.

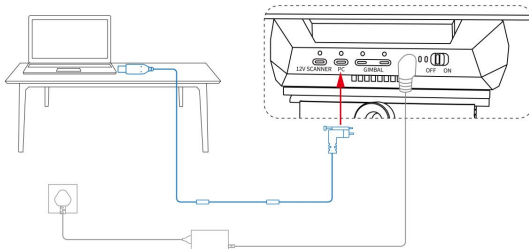
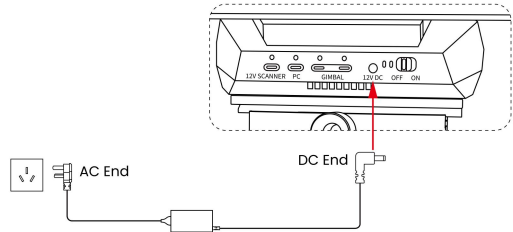

Step 2: Connect the PC Cable's L-shaped end to Tracker's "PC" port and tighten the screws. Insert the straight end into a USB Type-C port on your PC.

Connect Scanner

Connect the Scanner Cable's L-shaped end to Tracker's "12V SCANNER" port and tighten the screws. Connect the straight end to the USB Type-C port on the Scanner and tighten the screws.

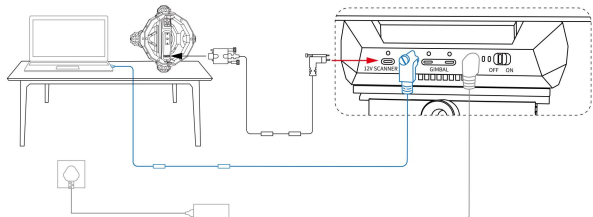

Power Trackit

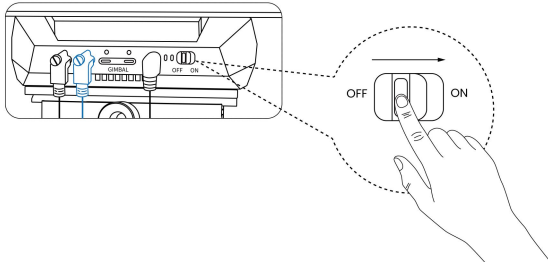

Turn on the power switch on the Tracker's back. When the right LED turns green and the software interface shows Scanner and Tracker connected, it's ready.

Secure the Cables

Step 1: Choose a smooth, flat surface and clean it thoroughly for a good seal. Ensure the sealing edge of the Suction Cup Cable Holder is intact to prevent air leaks.

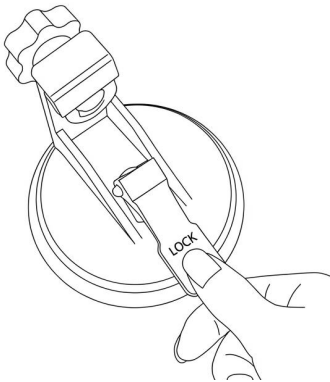

Step 2: Place the Suction Cup Cable Holder and press the locking knob to secure it.

Step 3: Attach the cables to the holder in the correct order. Adjust the clamping knob to secure the cables.

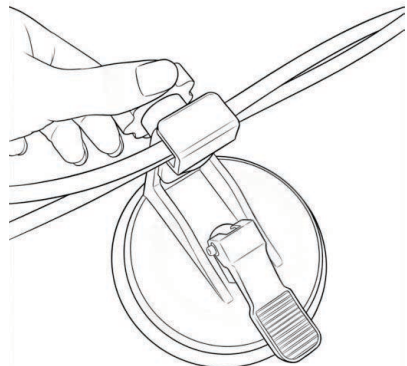

Calibration

Calibration Cautions:

- Calibrate your Trackit before your first use, after scanning environment/temperature changes, or when high-accuracy scan is required.
- Trackit offers two calibration options: desktop and ground. Choose the one that best suits your workplace. Refer to the Trackit User Manual for operation details.
- Ensure the Tracker and Scanner's cameras are not blocked during the whole process.
- To get accurate calibration results, ensure that only the markers on the Calibration Pole and Board are captured.
- Don't move the device while it indicates "Calibration in progress."

Scanner Calibration

- 1) **Install and Connect Tracker and Scanner:** Refer to the last chapter.
- 2) **Temperature Check:** Open the software, and click the "Scanner Calibration" in the bottom left corner to enter the calibration program. Then, the software will automatically detect the temperature of both the Tracker and Scanner.
- 3) **Import SN Info:** When the temperature detection is passed, follow the on-screen prompts to insert the USB Flash Drive into your PC. Then, scan the QR codes on the Calibration Pole and the Calibration Board to import their SN info.
- 4) **Scanner Calibration:** Place the Calibration Board flat on the table with the white side facing up. Hold the Scanner, and follow the on-screen calibration prompts.



Tracker Calibration

- 1) **Connect Tracker Gimbal:** Connect Tracker and its gimbal with the Tracker Gimbal Cable (short yellow cable).
- 2) **Install and Connect Scanner Gimbal:** Install the Scanner Gimbal onto the Scanner Tripod with its bolt. Connect the Tracker and the Scanner Gimbal using the Scanner Gimbal Cable (long yellow cable). Attach the cable to the Scanner Tripod using cable ties to prevent tangling with the Calibration Pole during calibration.
- 3) **Install the Calibration Pole:** Mount the Calibration Pole onto the Scanner Gimbal. Keep the Calibration Pole upright with the inclined surfaces facing the table.

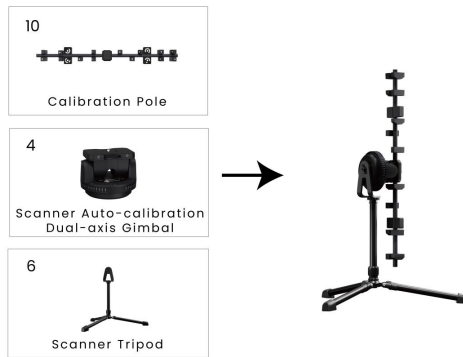

- 4) **Tracker Calibration:** Position the Scanner Tripod with the Calibration Pole facing the Tracker. Adjust the Tracker Tripod's height to ensure the Tracker captures the Calibration Pole. Then, following the software prompts, calibrate the Tracker at different distances.



Hand-Eye Calibration

- 1) **Place the Positioning Pad:** Unfold the Positioning Pad on the table. Position the Scanner and Calibration Board Tripods as shown on the Positioning Pad.

- 2) **Install the Calibration Board:** Place the Calibration Board into its tripod with the black side facing the Scanner and the markers side facing the Tracker. Ensure no markers are blocked during the placement.

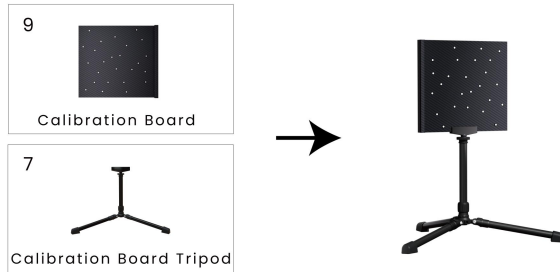

- 3) **Install the Scanner:** Remove the Calibration Pole from the Scanner Gimbal. Then, connect the Scanner to the gimbal using the Scanner Adapter.

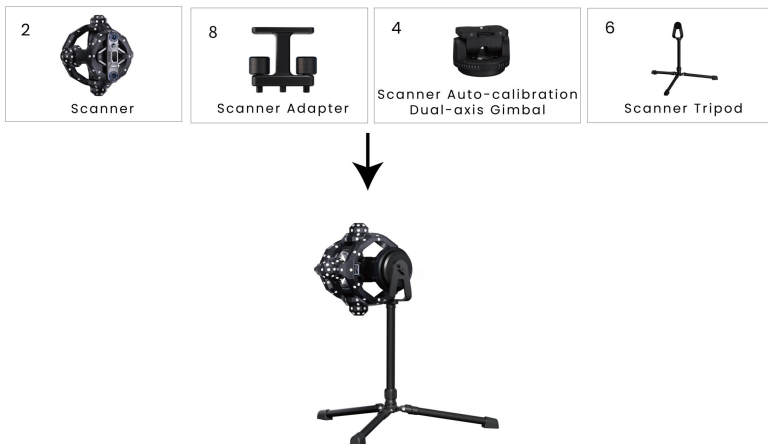

- 4) Once completed, place the Tracker and do the Hand-Eye Calibration following the on-screen prompts.

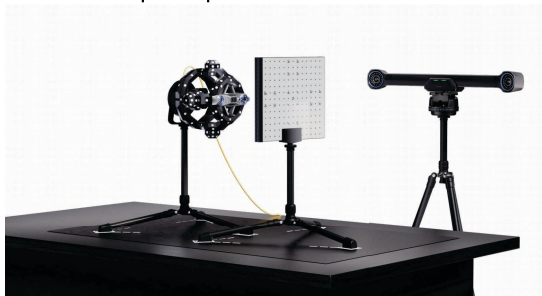

Watch the Tutorial Video in the software for detailed calibration steps.

Your First Scan

Track Scan

Scan without markers by tracking the Scanner's position and angle in real time. The Tracker and object must stay still during the scan, making it suitable for quickly scanning small and medium-sized objects.

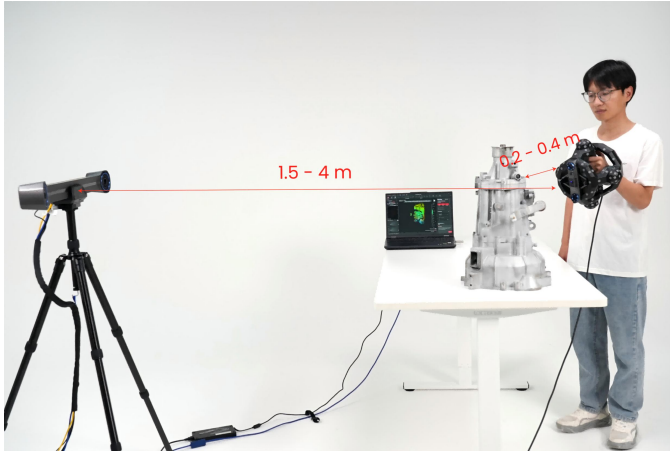

After connecting the scanner, click the New Project button on Revo Track's Home page to enter the project interface. Select "Track Scan" and perform your scan using the following steps:

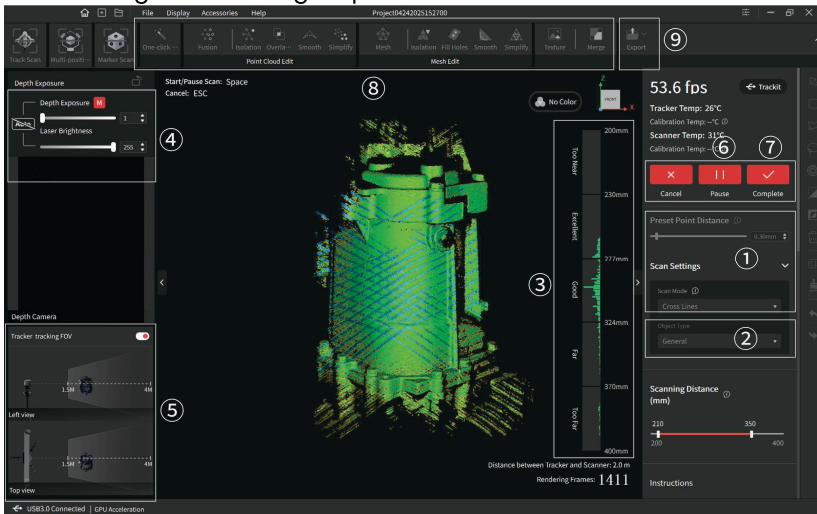



※ Please refer to the actual interface in Revo Track.

① In Scan Settings, select Cross Lines or Single Lines mode, and the point

distance as required.

- ② Select the Object Type according to your requirements.
- ③ Move the Scanner closer or further away from the object until the scanning distance indicator bar shows Excellent or Good.
- ④ Click the Auto button to automatically set the Depth Cameras' exposure. Or turn off the Auto exposure and adjust it by dragging the slider until the laser lines are clearly visible in the depth camera's preview window.
- ⑤ Adjust the distance between the Scanner and the Tracker to ensure the Scanner stays within the Tracker's FOV.
- ⑥ Click the  button to start the scan. During the scan, aim the Scanner at the object. Refer to the distance indicator bar to ensure an excellent distance. Hold the Scanner steadily over one area for a few seconds until the model surface is entirely blue. Then, move to the next area slowly and steadily.

Note: Don't block the Tracker's cameras during scanning, and ensure that the Tracker can clearly see the markers on the Scanner and the object.
 Try to ensure only the object is captured by the Scanner.
 The point cloud turns blue during the scanning process as more data is captured. A totally blue point cloud indicates higher point cloud quality.

- ⑦ Click the  button to pause and check your model anytime during the scan. If the model is incomplete, click the  button to continue your scan. Click the  button to finish the scan when the model is complete.
- ⑧ Click **One-click Edit** to process the model automatically, or manually edit the model using the Fusion and Mesh settings, and other tools if you need a more detailed model. When manually processing for point cloud fusion, it is suggested that the system's recommended point distance be used. Setting a very small point distance will lead to a long calculation time. For details, please refer to the User Manual on Revo Track's learning page.
- ⑨ After post-processing, export the model in formats such as PLY, OBJ, or STL.

Multi-position Scan

Ideal for scanning large objects like cars and industrial parts. Before scanning, divide surfaces into distinct areas. During each area scan, capture global markers after moving the Tracker, then capture the point cloud. Ensure at least five markers or Anchor Blocks are always seen when moving the Tracker.

After the scanner is connected, click the New Project button on Revo Track’s Home page to enter the project interface. Select “Multi-position Scan” and follow the steps below to start your scan:

Note: Below is the scanning workflow. Refer to the Trackit User Manual for detailed instructions.

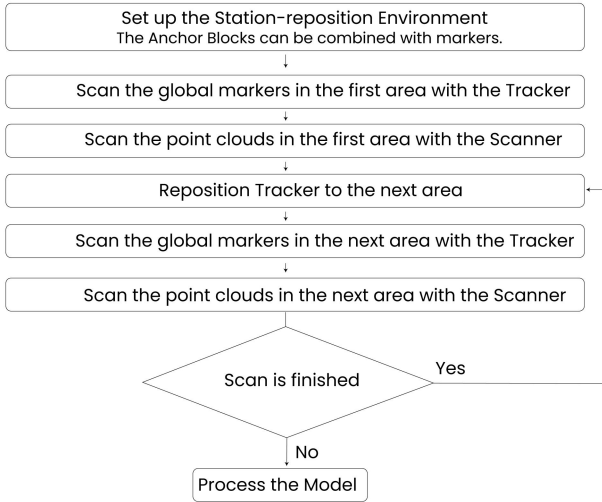

Marker Scan

The Scanner also functions as a standalone 3D scanner, but it requires markers to be placed on the objects for the scan to be performed successfully. It’s suitable for scanning small and medium-sized objects.

After the scanner is connected, click the New Project button on Revo Track’s Home page to enter the project interface. Select “Marker Scan” and follow the steps below to start your scan:

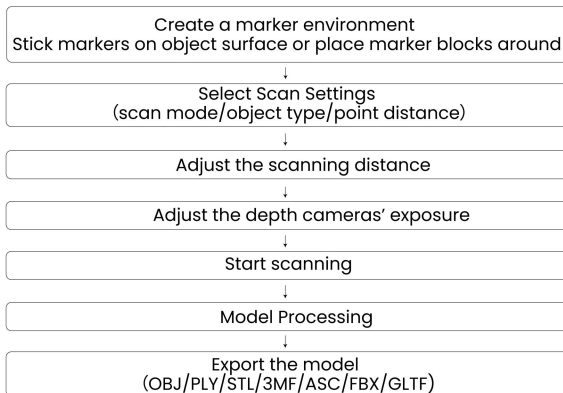

Appendix I: Specifications

Revopoint Trackit Tracking 3D Scanner	
Scanner	
Single-frame Accuracy	0.02 mm
Fused Point Distance, up to	0.05 mm
Scanning Speed, up to	1,500,000 Point/s
Light Source	30 Blue Cross Laser Lines 1 Blue Single Laser Line
Working Distance	200 - 400 mm
Single Capture Area at Nearest Distance	160 × 70 mm @ 200 mm
Single Capture Area at Furthest Distance	320 × 215 mm @ 400 mm
Weight	1.2 kg
Dimensions (L × W × H)	295 × 295 × 205 mm
Operating Temperature Range	0 - 40 °C
Output Formats	PLY, OBJ, STL, ASC, 3MF, GLTF, FBX
Material	Frame: Carbon Fiber Housing: Polycarbonate
Tracker	
Part Size Range (Recommended)	0.01 - 6 m
Volumetric Accuracy (Tracking system)	0.02 mm + 0.04 mm × L (m)
Working Distance	1500 mm - 4000 mm
Minimum Tracking Frame	1304 × 1067 mm @ 1500 mm
Maximum Tracking Frame	3260 × 2845 mm @ 4000 mm
Tracking Volume	11 m ³
Weight	2.0 kg
Dimensions (L × W × H)	686 × 106 × 111 mm
Tracking Band	Infrared
User Recalibration	Auto Calibration Tracker has an auto gimballed calibration system. The Scanner requires manual calibration.
Supported Accessories	Calibration Board, Calibration Pole, Auto Calibration Dual-axis Gimbal, Anchor Block, Large Turntable

*Product specifications are subject to the information on the official website.

Appendix 2: Mounting Hole Diagram

Scanner Adapter Hole Diagram

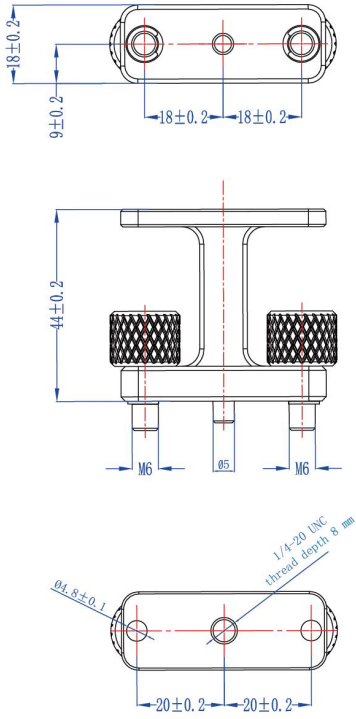

Scanner External Port Diagram

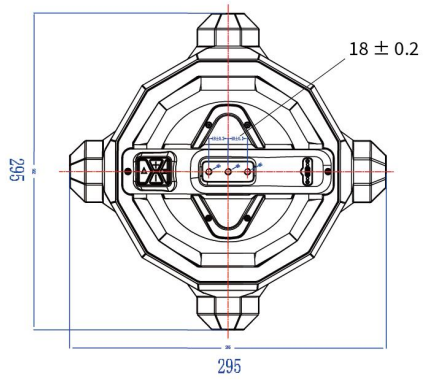

IC Warning

This device complies with Industry Canada's license-exempt RSS standard (s). Operation is subject to the following two conditions:

- (1) this device may not cause interference, and
- (2) this device must accept any interference, including interference that may cause undesired operation of the device.

This Class B digital apparatus complies with Canadian ICES-003.

IC RF Statement:

When using the product, maintain a distance of 20cm from the body to ensure compliance with RF exposure requirements.

FCC Warning

This device complies with part 15 of the FCC Rules. Operation is subject to the following two conditions:

- (1) This device may not cause harmful interference, and
- (2) this device must accept any interference received, including interference that may cause undesired operation.

Any Changes or modifications not expressly approved by the party responsible for compliance could void the user's authority to operate the equipment.

Note: This equipment has been tested and found to comply with the limits for a Class B digital device, pursuant to part 15 of the FCC Rules. These limits are designed to provide reasonable protection against harmful interference in a residential installation. This equipment generates uses and can radiate radio frequency energy and, if not installed and used in accordance with the instructions, may cause harmful interference to radio communications. However, there is no guarantee that interference will not occur in a particular installation. If this equipment does cause harmful interference to radio or television reception, which can be determined by turning the equipment off and on, the user is encouraged to try to correct the interference by one or more of the following measures:

- Reorient or relocate the receiving antenna.
- Increase the separation between the equipment and receiver.
- Connect the equipment to an outlet on a circuit different from that to which the receiver is connected.
- Consult the dealer or an experienced radio/TV technician for help.

This equipment complies with FCC radiation exposure limits set forth for an uncontrolled environment.

This equipment should be installed and operated with a minimum distance of 20cm between the radiator & your body.

Tutorial Videos:



Contact Us:



Scan the QR code with your
phone to contact us.