



www.mintion.net



SHENZHEN MINTION TECHNOLOGY CO., LTD

Distribution: sales@mintion.net

Support: support@mintion.net

FB Group: Mintion Official Group (Beagleprint)



BEAGLE CAMERA

Quick Guide Manual

SPECIFICATION

Part Number	Beagle
Night Version	Yes
Frame Rate	Up to 25fps
Upload Printable File	Yes, Only gcode files
Connect to Printer	USB Cable
Video Compress	H.264/MJPEG
Camera Resolution	Up to 1080P
Auto Time-lapse Video	Yes
Temperature Monitor	Yes, for Hot End & Hot Bed
WiFi Connectivity	Supports 2.4 GHz 802.11g/n
Power Source	Plug-in
Weight	130g

PACKING LIST



Beagle camera



Power Plug x1



Type C Cable 1.5M x1
(For power)



USB-Micro-B Cable 1M x1
(Connect to printer)



Micro SD Card x1

(Insert in camera)



Reset Needle x1



Quick Guide Manual x1

CAMERA INTRODUCTION

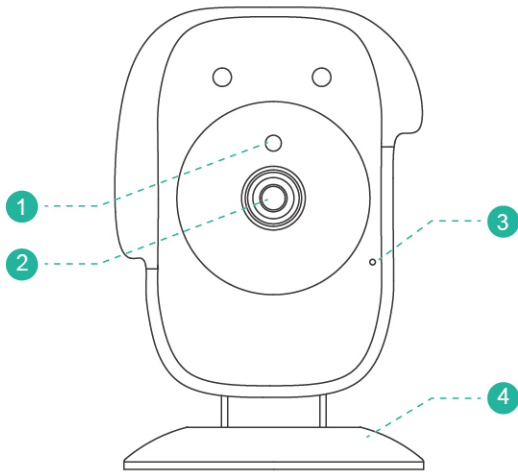

- 1 IR-Cut Sensor
- 2 Lens
- 3 Microphone
- 4 Camera Base

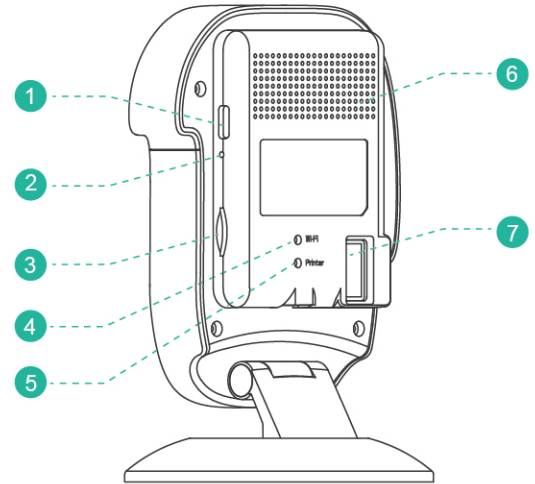

- 1 Type-C Socket (Power)
- 2 Plug and hold for 5 seconds, and you will hear the voice of "Successfully resetting the camera", then the camera will be reset and restart.
- 3 Micro SD Slot
- 4 WiFi Indicator < **Solid Green:** WiFi connected
Flashing Green: WiFi disconnected
- 5 Printer Indicator < **Solid Red:** Printer connected
Flashing Red: Printed disconnected
- 6 Speaker
- 7 USB Socket

CONNECTION

Connecting Cables

Plug the power cable into the camera and the power adaptor, then into a power outlet, plug the USB-Micro-B Cable into the camera and the 3d printer, as shown in the figure below.

(The camera will take 1-2 minutes when power-up, don't cut off the power during this period.)

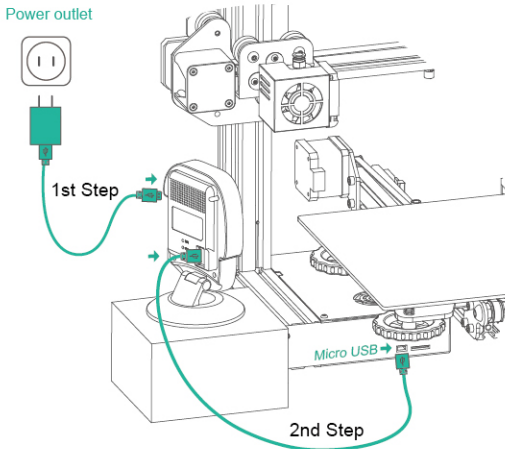

Connect to Printer

Plug the USB-Micro USB cable into the camera and the printer, as shown in the figure above.

Put on Camera

You could put the camera onto the box on the printer's front side, as shown below.

*You need to use a USB 2.0 Hi-Speed cable if your printer is with Hi-Speed 2.0 slot.
(Please make sure your cable has the function of transferring data)

APP DOWNLOAD & REGISTRATION

Please scan the QR Code to reach the App download page, then download from App Store, Google Play or download the APK directly. After download, click to run the app and make the registration.

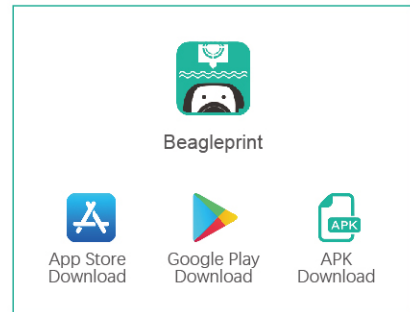

USE THE APP

Use your phone to connect to the camera hotspot.

Please DO NOT cut off the power of the Beagle camera when it's working; DO NOT disconnect the camera from the printer when it is connected to the printer and transmit printable files through the camera for 3d printing.

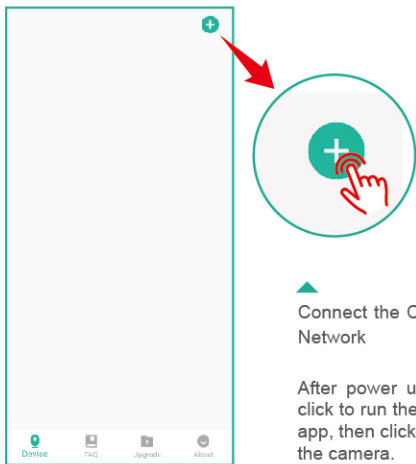

Connect the Camera to WiFi Network

After power up the camera, click to run the "Beagleprint" app, then click "+" icon to add the camera.



QR Scan Configuration

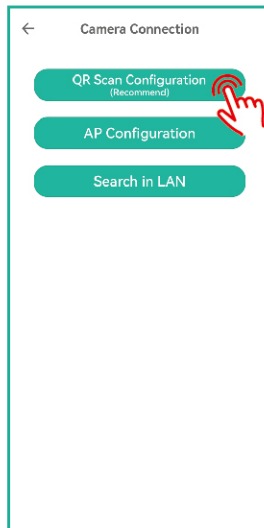

Power up the camera and ensure you have heard the remind voice. If not, please select you didn't hear and reset the camera.

Select the "QR Scan Configuration" to add the camera.

Make sure the power is not being cut off during the configuration.

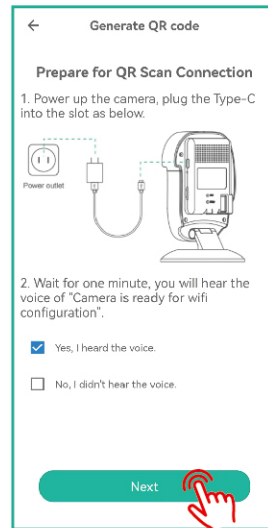

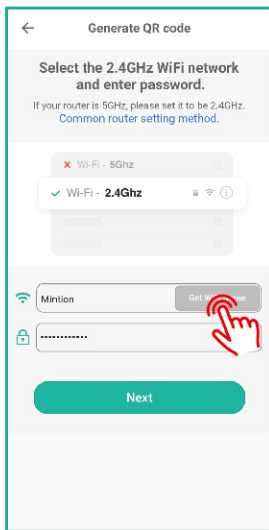

◀ With the permission, the app will automatically get the WiFi name of your phone connected. Please enter the exact password of WiFi.

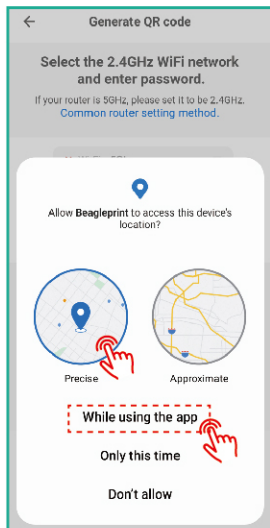

▶ Please give the permissions to the app, especially for the Precise Location.

⚠ Main reason fails to WiFi connection is the wrong password.

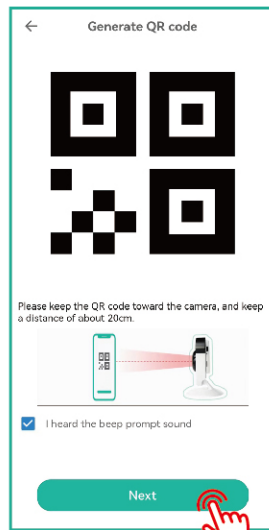

◀ Hold the phone straightly in the front of Beagle camera about 20cm distance, then you will hear a prompt sound of scanning, then Click to next.

▶ The camera will automatically connect to the WiFi network. Please wait for 1-2 minutes. After connection, the camera will switch automatically.

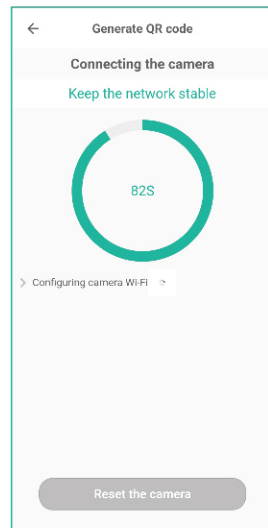

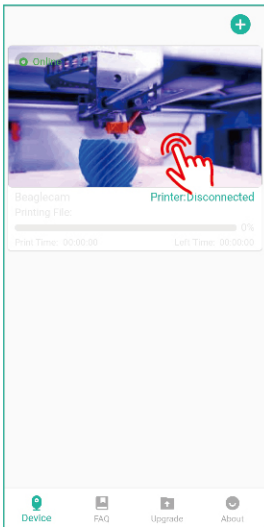

▶ The camera is Online and click to log in to check the video.

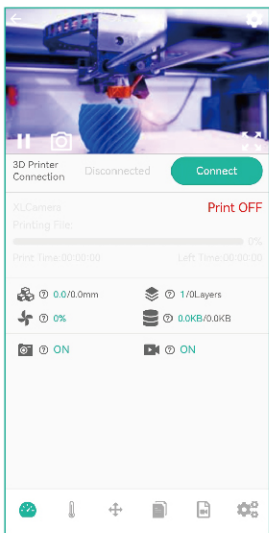

You can find the video stream ▶ and printer status.

Note: If the camera cannot connect to wifi with the QR Scan Configuration, please reset the camera and click the AP Configuration to connect to the wifi.



AP Configuration

Select the "AP Configuration" to add the camera.

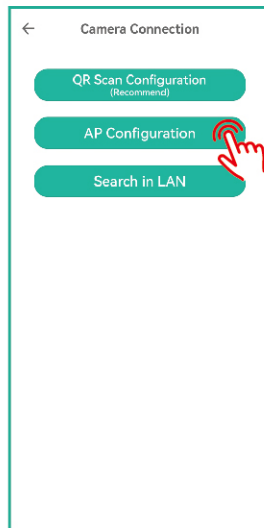

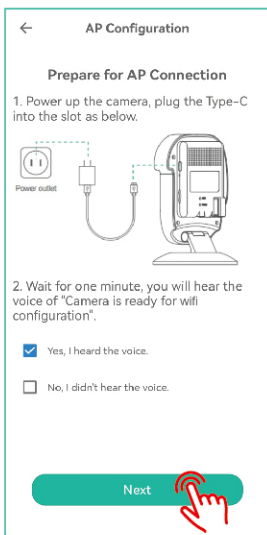

▶ Make sure the power is not being cut off during the configuration.

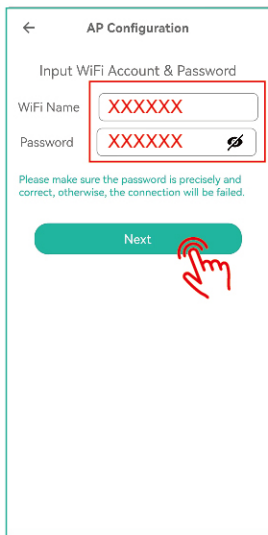

▶ Select your WiFi and then input the password to save the WiFi information in the app.

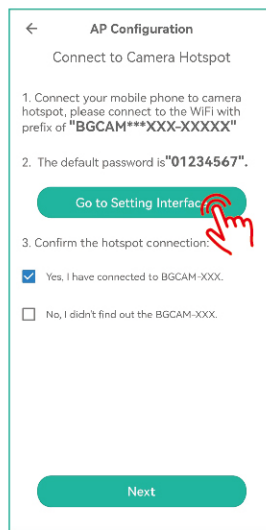

▶ Go to the "Setting" interface of your mobile phone to connect the camera hotspot.

▶ The camera will automatically connect to the WiFi network. Please wait for 1-2 minutes.

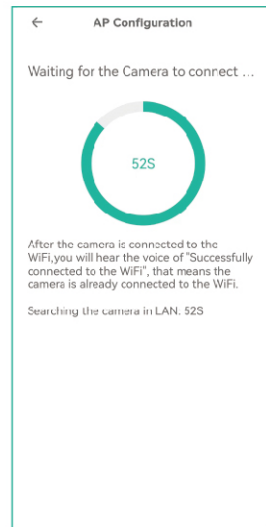

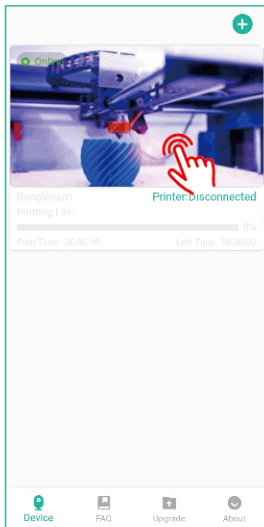

◀ The camera is Online and click to log in to check the video.

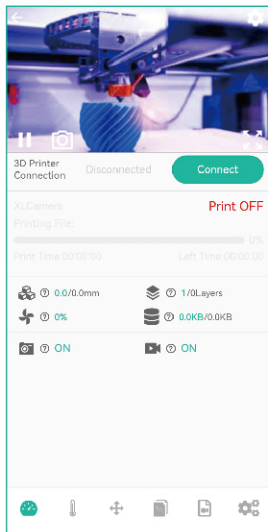

▶ You can find the video stream and printer status.



IP address of Camera

When the Beagle camera is successfully connected with your mobile phone in the Beagleprint, you will find the camera IP address in the camera setting page. Please follow the steps to access:

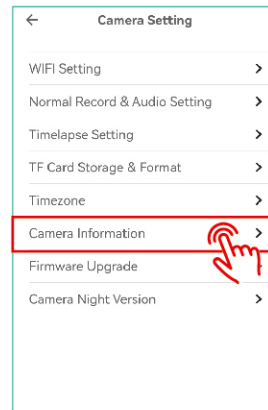
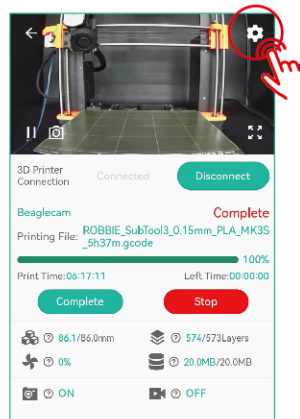

Camera Information	
Camera ID	MKFC-115344-WVYPB
Camera Model	Beagle
Current Firmware	1.1.6
User Online	2
Mac Address	0C:8C:24:9F:C2:FD
IP Address	192.168.0.8
Subnet Mask	255.255.255.0
Gateway	192.168.0.1
DNS1	192.168.0.1
DNS2	192.168.0.1

Restart Camera

Reset Camera (Saved WiFi)

Reset Camera (No WiFi)

With this information, you can input the IP address in browser to login the camera. Please make sure your computer is in the same LAN with the Beagle camera.

🔒 192.168.0.8

Please sign in

Account

Password

Remember Me

[Login](#)

The default account and password of camera is "admin".

The default account and password is "admin", then you will get the interface as belows:



Upload the code

Please click the "Upload" icon to upload the gcode files on the browser or beagleprint APP, and click the "Print" icon to start printing. Note: Please upload the gcode file to the SD card of the camera and start printing with the camera, otherwise it will affect some functions of the camera.

ATTENTION

Please **DO NOT** cut off the power of the Beagle camera when it's connecting to the 3d printer on printing; **DO NOT** disconnect the camera from the printer when it is connected to the printer and transmit gcode files through the camera for printing. Otherwise, it will cause printing failure and damage the camera's firmware. In this case, the camera cannot work typically; this problem is the user problem, not a quality problem. Hence, please ensure that you cannot disconnect the camera from the power supply and the USB cable connected to the printer when the camera is working, and the 3d printer is printing.

The Beagle camera only supports one printer connection for control, allowing four users to simultaneously log in and access the camera (including mobile phone and computer users). Therefore, please make sure it's securely accessing the device to prevent bad guys from accessing the camera or printer and the environment to cause damage.

At the same time, we recommend that you do not let the 3d printer perform the 3d printing work completely unattended. Please come to the printer and watch the real printing progress of the printer regularly to prevent further deterioration of the situation when an abnormal condition occurs.

This camera shortens the distance between the user and the printer. The user is obliged to ensure the reasonableness and legality of the use of the product and avoid infringement of third-party rights, including but not limited to publicity rights, intellectual property rights, data rights, or privacy rights. At the same time, since the customers' use and storage of this camera are beyond our control, we are not responsible for possible personal injury or property loss.

This manual is for reference only. In any case, we have the right to modify and improve it without notifying users. If you want to know the latest instruction manual, you can go to the official website for more information.

FCC WARNING STATEMENT

Changes or modifications not expressly approved by the party responsible for compliance could void the user's authority to operate the equipment. This equipment has been tested and found to comply with the limits for a Class B digital device, pursuant to Part 15 of the FCC Rules. These limits are designed to provide reasonable protection against harmful interference in a residential installation. This equipment generates uses and can radiate radio frequency energy and, if not installed and used in accordance with the instructions, may cause harmful interference to radio communications. However, there is no guarantee that interference will not occur in a particular installation. If this equipment does cause harmful interference to radio or television reception, which can be determined by turning the equipment off and on, the user is encouraged to try to correct the interference by one or more of the following measures: ealer or an experienced radio/TV technician for help.

- Reorient or relocate the receiving antenna.
- Increase the separation between the equipment and receiver.
- Connect the equipment into an outlet on a circuit different from that to which the receiver is connected.
- Consult the dealer or an experienced radio/TV technician for help.

FCC RADIATION EXPOSURE STATEMENT

The antennas used for this transmitter must be installed to provide a separation distance of at least 20 cm from all persons and must not be co - located for operating in conjunction with any other antenna or transmitter.





FAQS

What's the maximum storage of the TF card I can use for this camera?

The maximum storage is 128GB.

What's the camera lens? And what's the distance?

The beagle camera is using the fixed lens, and the focus distance is 20cm.

How can I connect the Beagle camera to the printer?

We provide the default micro USB to USB cable in box to connect to the printer, if your printer is using a Hi-speeding 2.0 socket, you have to purchase one Hi-speeding 2.0 to USB cable.

Plug the USB side cable into the USB socket on the back panel of the camera, and the micro USB is plugged into the printer. After the camera is connected to the WiFi, then click to run the app Bealgeprint and click the "Connect" button under the camera review window. Before connecting to the printer, you need to select the brand and model of printer to confirm the printed size.

Why I can't connect the camera to my 3d printer?

There're few reasons to check on this problem, but make sure your 3d printer is power up:

1. Ensure the USB cable from the Beagle camera to your 3d printer is supported to transmit the data, not just for charging.
2. Please check if your 3d printer is on the compatible 3d printers list, while the Beagle camera is an ongoing project, we will upgrade the firmware to more 3d printers on compatibility regularly.

Why my Beagle camera is not generate the time-lapse video?

Please ensure that the time-lapse video function is in "ON" status, in the default setting, it's on. And please check what slicer you are using, now the Beagle camera is compatible with Ultimate Cura, Creatly Slicer, Simplify3D, Prusaslicer and Superslicer. If you are using a different slicer, and the system of the camera is not able to identify the layer description, then it won't send the commands to the printer to move the hotend to capture an image, then it won't generate the time-lapse video automatically.

GUIDELINES OF BEAGLE CAMERA

QR Scan Configuration for wifi Network



Mounting brackets of Beagle camera



Firmware Upgrade



Setup for Time-lapse Video



IP Address on PC



3D Printers of Compatibility



WiFi Connection by SD Card



Adjust the lens of Camera



Unboxing and Setup

